

SCREW/WING NUT
GHIERA A FARFALLA/ACCIAIO
WING NUT/STEEL
FLÜGELMUTTERHÜLSE/STAHL
ECROU PAPILLON/ACIER

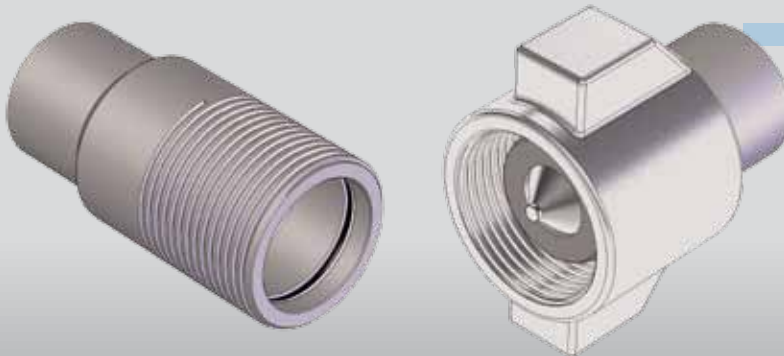

Caratteristiche tecniche

- Intercambiabilità: Snap-Tite 75
- Occlusione: valvola
- Aggancio: a vite
- Materiale: acciaio
- Finitura acciaio: Zn-Fe (Cr III)
- Filettature: NPT
- Guarnizioni standard: NBR
- Temperatura d'esercizio: -25 °C +100 °C
- Guarnizioni opzionali: FKM, EPDM o altro
- Pressioni di esercizio: 350 bar
- Connessione in pressione: consentita (lato maschio o lato femmina)
- Massima pressione residua: 100 bar

Nominal size				Max working pressure	Rated flow	Max flow rate	Min burst pressure			Fluid spillage
							Male	Female	Coupled	
DNP	BG	ISO	mm	MPa	l/min	l/min	MPa	MPa	MPa	cc
20	4	19	17	35	106	190	75	140	150	8
25	5	25	22	35	189	280	90	150	160	16
30	6	31.5	27	35	288	480	85	160	130	31
39	7	40	34	35	379	700	60	90	120	64
50	8	50	47	35	757	1000	50	60	110	141

1 MPa = 145,04 psi • 1 l = 0,264 gal

Technical data

- Interchange: Snap-Tite 75
- Occlusion: poppet
- Locking: screw
- Material: steel
- Steel finishing: Zn-Fe (Cr III)
- Threads: NPT
- Standard seals: NBR
- Working temperature: -25 °C +100 °C
- Optional seals: FKM, EPDM or more
- Working pressure: 350 bar
- Connection under pressure: allowed (both male or female side)
- Max residual pressure: 100 bar

Technische Merkmale

- Austauschbarkeit: Snap-Tite 75
- Verschluss: ventil
- Kupplung: Schraubweise
- Werkstoff: Stahl
- Stahl Ausführung: Zn-Fe (Cr III)
- Gewinde: NPT
- Standard-Dichtungen: NBR
- Betriebstemperatur: -25 °C +100 °C
- Dichtungen nach Wahl: FKM, EPDM, usw.
- Betriebsdruck: 350 bar
- Kuppeln unter Druck: erlaubt (Steckerseite oder Muffeseite)
- Max. Restdruck: 100 bar

Caracteristiques techniques

- Intercambiabilità: Snap-Tite 75
- Obturation: clapet
- Accrochage: a vissé
- Matériel: acier
- Traitement acier: Zn-Fe (Cr III)
- Taraudage: NPT
- Joints standard: NBR
- Température de service: -25 °C +100 °C
- Joints facultatifs: FKM, EPDM, ect.
- Pression de service: 350 bar
- Connexion sous pression: possible (côté male ou femelle)
- Pression restante max: 100 bar

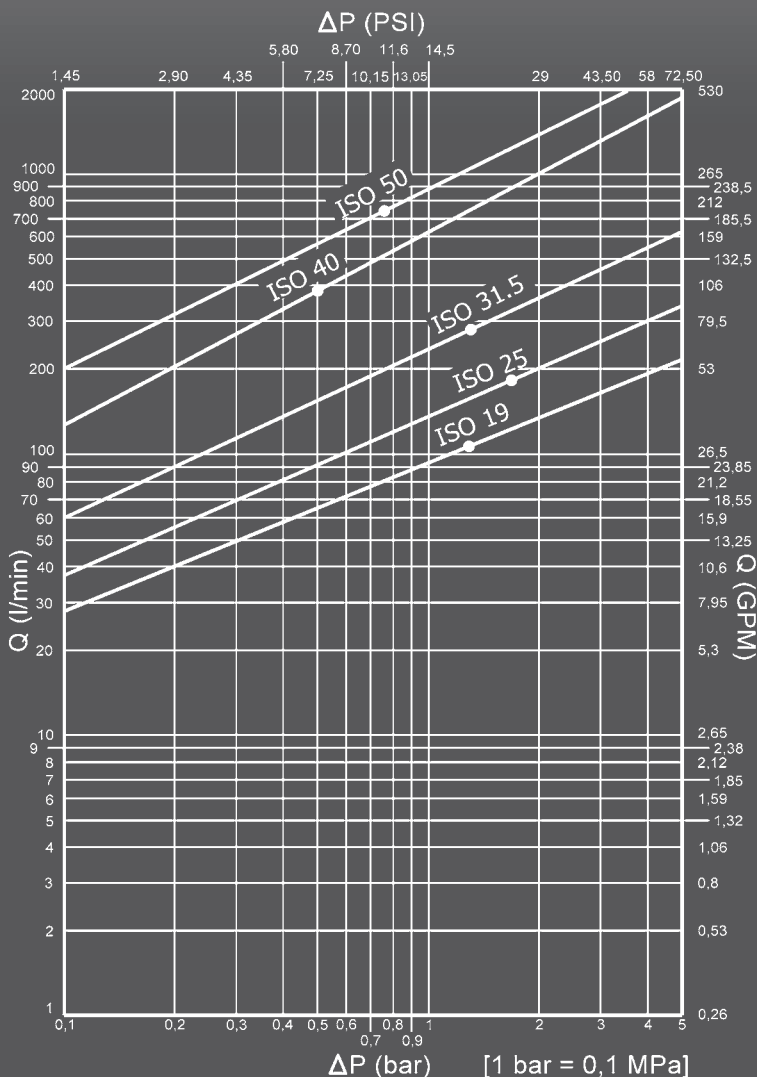

VFH1 DN20 - BG 4 - ISO 19

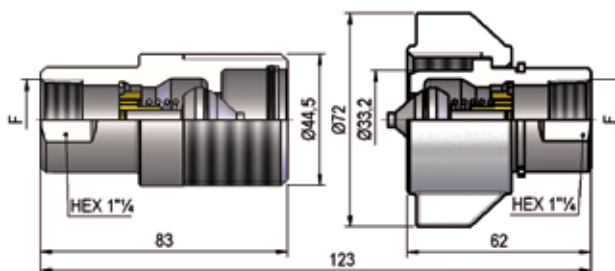

F	STANDARD	FEMMINA - FEMALE - MUFFE - FEMELLE			MASCHIO - MALE - STECKER - MALE		
		COD. F	Weight (g)	Packaging (pcs.)	COD. M	Weight (g)	Packaging (pcs.)
NPT 3/4"	ANSI B1.20.3	VFH1.2019.012	480	28	VFH1.2019.013	840	12

VFH1 DN25 - BG 5 - ISO 25

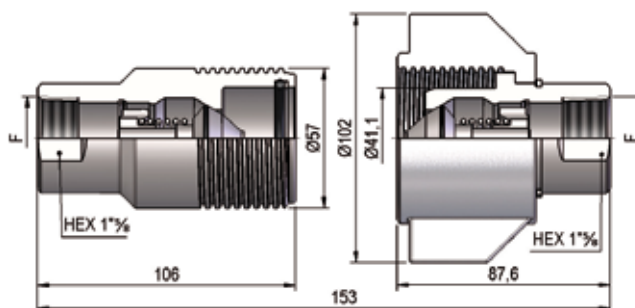

F	STANDARD	FEMMINA - FEMALE - MUFFE - FEMELLE			MASCHIO - MALE - STECKER - MALE		
		COD. F	Weight (g)	Packaging (pcs.)	COD. M	Weight (g)	Packaging (pcs.)
NPT 1"	ANSI B1.20.3	VFH1.2525.012	1100	15	VFH1.2525.013	1145	8

VFH1 DN30 - BG 6 - ISO 31.5

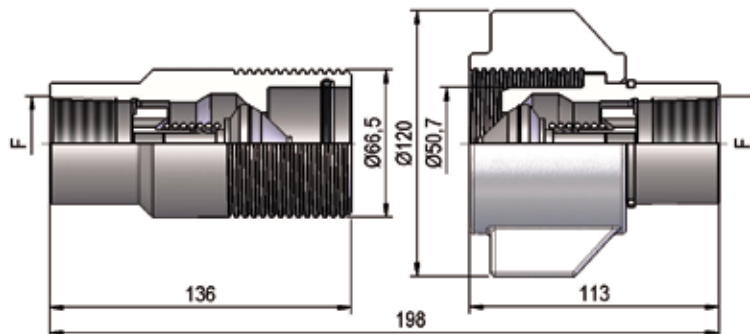

F	STANDARD	FEMMINA - FEMALE - MUFFE - FEMELLE			MASCHIO - MALE - STECKER - MALE		
		COD. F	Weight (g)	Packaging (pcs.)	COD. M	Weight (g)	Packaging (pcs.)
NPT 1 1/4"	ANSI B1.20.3	VFH1.3031.012	1870	6	VFH1.3031.013	2530	6

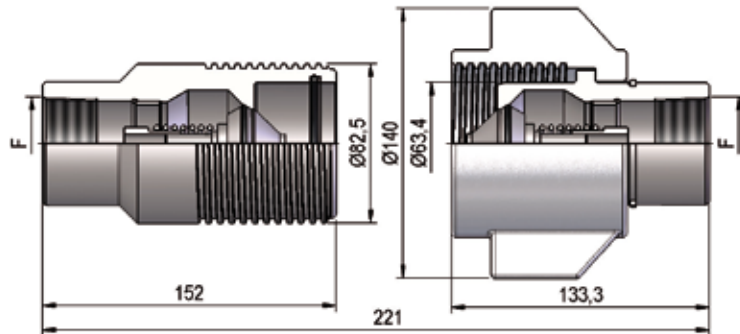
VFH1 DN39 - BG 7 - ISO 40

F	STANDARD	FEMMINA - FEMALE - MUFFE - FEMELLE			MASCHIO - MALE - STECKER - MALE		
		COD. F	Weight (g)	Packaging (pcs.)	COD. M	Weight (g)	Packaging (pcs.)
NPT 1"½	ANSI B1.20.3	VFH1.3939.012	3100	6	VFH1.3939.013	4010	4

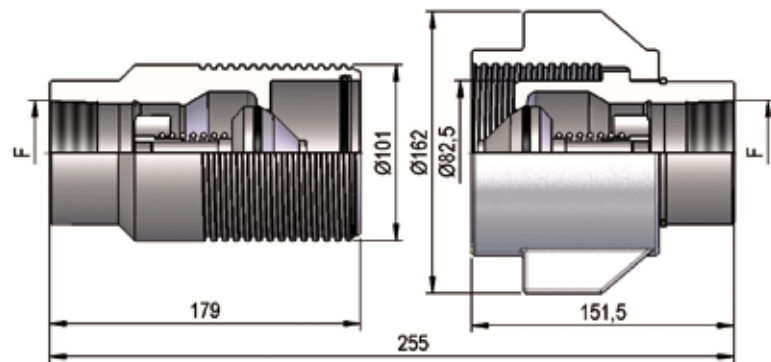
VFH1 DN50 - BG 8 - ISO 50

F	STANDARD	FEMMINA - FEMALE - MUFFE - FEMELLE			MASCHIO - MALE - STECKER - MALE		
		COD. F	Weight (g)	Packaging (pcs.)	COD. M	Weight (g)	Packaging (pcs.)
NPT 2"	ANSI B1.20.3	VFH1.5051.012	5570	4	VFH1.5051.013	7935	2

METAL CAPS

* REALIZZATI SU RICHIESTA DEL CLIENTE
 AVAILABLE ON REQUEST
 AUF ANFRAGE LIEFERBAR
 DISPONIBLES SUR DEMANDE

NOMINAL SIZE			FEMALE DUST PLUG					MALE DUST CAP					MATERIAL
DNP	BG	ISO	COD. F	Dimensions			Weight	COD. M	Dimensions			Weight	
				D	L	D1	(g)		D	L	D1	(g)	
20	4	19	SVFH.20202*	-	-	-	-	SVFH.20203*	-	-	-	-	Aluminum
25	5	25	SVFH.25202	70	270	48	212	SVFH.25203	69,5	270	48	247	Aluminum
30	6	31.5	SVFH.30202	80,5	270	49	314	SVFH.30203	75,5	270	49	389	Aluminum
39	7	40	SVFH.39202	96	280	48	503	SVFH.39203	95,5	280	48	694	Aluminum
50	8	50	SVFH.50202*	-	-	-	-	SVFH.50203*	-	-	-	-	Aluminum

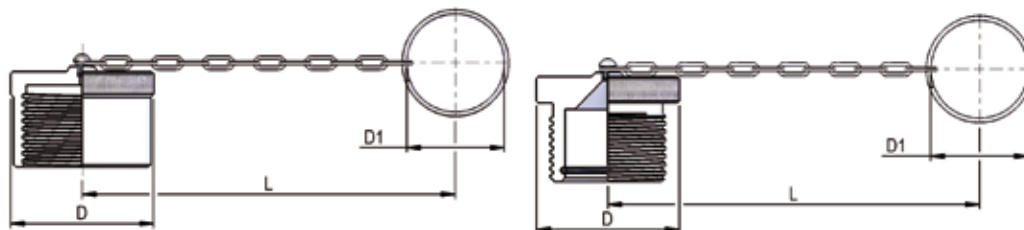

SPARE PARTS



NOMINAL SIZE			FEMALE GASKET	
DNP	BG	ISO	OR (NBR*)	BK (PTFE)
06	1	6.3	VFH.019.120	VFH.019.130
10	2	10	VFH.025.120	VFH.025.130
13	3	12.5	VFH.030.120	VFH.030.130
20	4	20	VFH.031.120	VFH.031.130
25	5	25	VFH.039.120	VFH.039.130

* AL CODICE DELLA GUARNIZIONE IN NBR AGGIUNGERE 'E' PER EPDM O 'V' PER VITON
 TO THE NBR GASKET CODE ADD 'E' FOR EPDM OR 'V' FOR VITON
 ZU DER ARTIKELNR. DER NBR DICHTUNG GEBEN SIE 'E' FUER EPDM ODER 'V' FUER VITON AN
 AU CODE DU JOINT EN NBR JOINDRE 'E' POUR EPDM OU 'V' POUR VITON